

TOOLS NEEDED

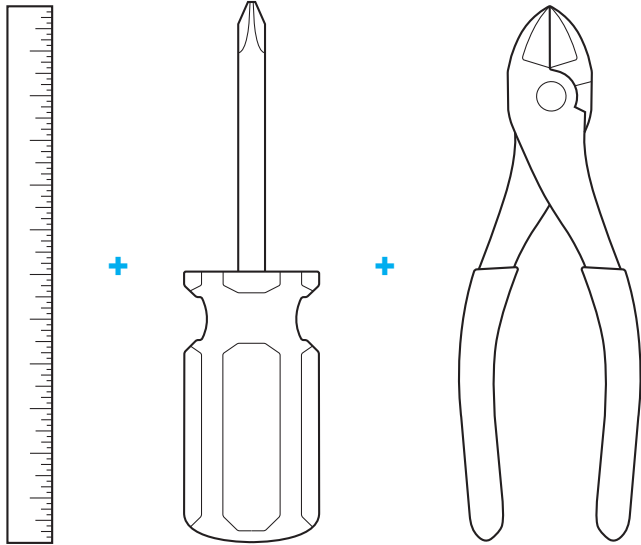

1: MEASURE

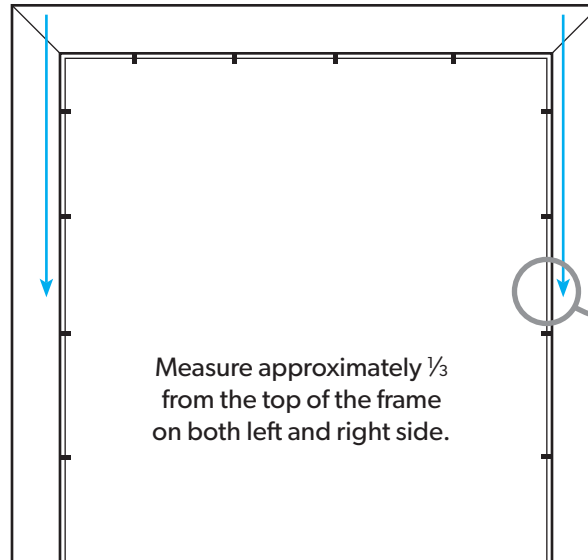

2: INSTALL D-RINGS

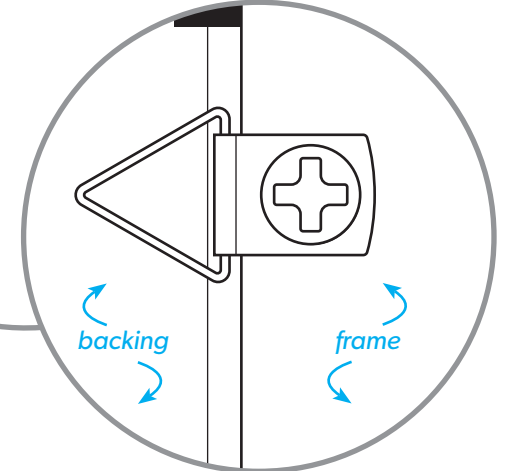

Place flat side of d-ring bracket on frame allowing d-ring to hang over backing. Secure in place with screw.

INCLUDED

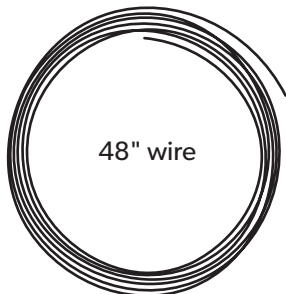
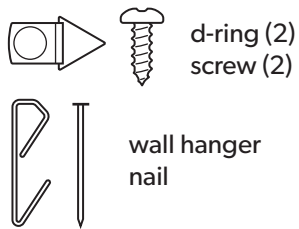

3: TIE WIRE

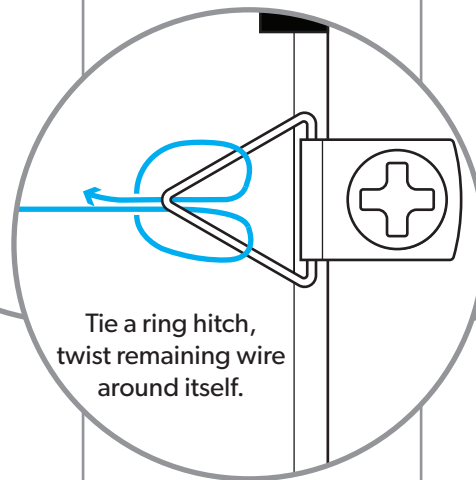
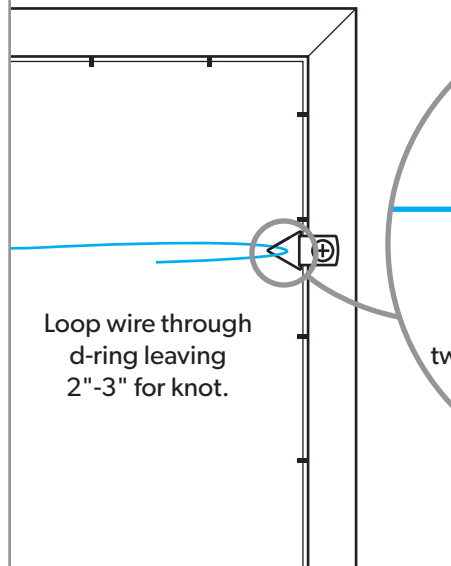

4: STRETCH + TIE WIRE

